

TIPS FOR RIDING IN TRAFFIC

BE CAUTIOUS ON SIDEWALKS

More bicycle accidents occur on sidewalks than in the street. This is because drivers often do not see bicyclists on sidewalks when making turns or exiting driveways. Be alert and ride defensively when you ride on sidewalks.

Knowing and following the rules of the road is not enough to keep you from being involved in a crash. Unfortunately, there are drivers who either do not know, understand or follow the rules. Knowing what other drivers do wrong, and watching for their mistakes, can help you reduce your chances of being in a crash.

Left turning motorist hits bicyclist going straight

Watch cars at intersections carefully. Make eye contact with drivers. Be visible. Ride further out in the lane as you approach intersections. Be prepared to stop or make an emergency turn if necessary.

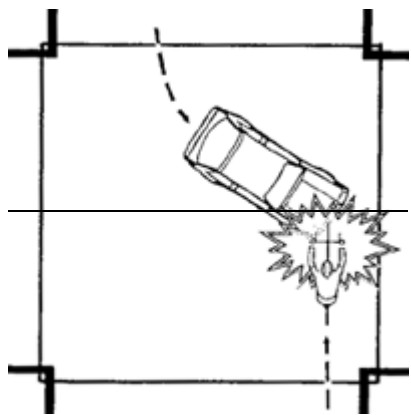

Motorist right-turn in front of bicyclist

Be alert for drivers speeding up then slowing down as they pass you. Do not pass cars on the right near intersections, you will be in the driver's blind spot. Do not rely on other drivers' turn signals.

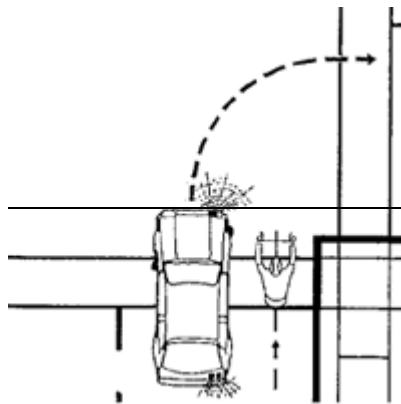

Motorists drive out from a driveway, alley, parking space or stop sign

Proper lane position, careful scanning and an all-around conspicuous appearance will help you avoid these situations. If you ride on sidewalks, be extra alert when crossing driveways and intersections.

Most drivers do not check for bicyclists on sidewalks.

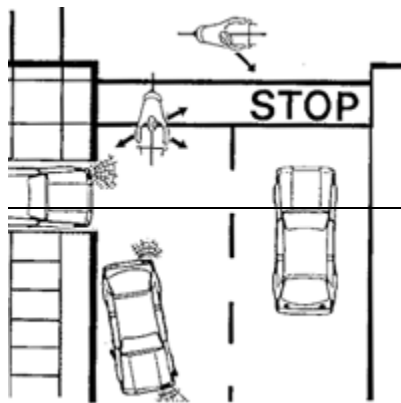

Obey all traffic signs and signals

They apply to all vehicles, including bicycles. Obeying the law is the best way to gain respect from other road users. Bicyclists can be ticketed for traffic violations.

Always ride with traffic

Riding against traffic is unpredictable. Drivers turning at intersections, exiting driveways or leaving parking spaces are not expecting wrong way bicyclists.

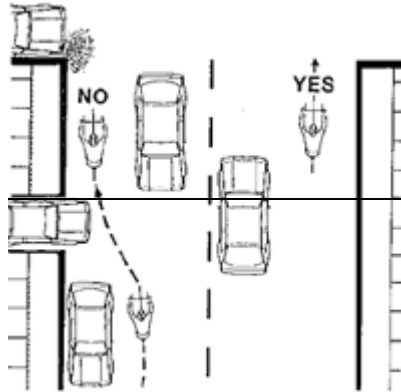

Ride as far to the right as practicable

Also stay far enough away from the curb to avoid hazards. Ride three feet from parked cars to avoid a suddenly opened car door, and ride in a straight line.

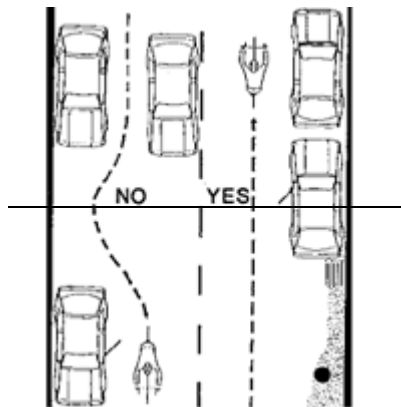

Ride further out in the lane

Ride further out in the lane when traveling at the same speed as other traffic, when the lane is too narrow to safely share with cars, and when approaching intersections to be more visible.

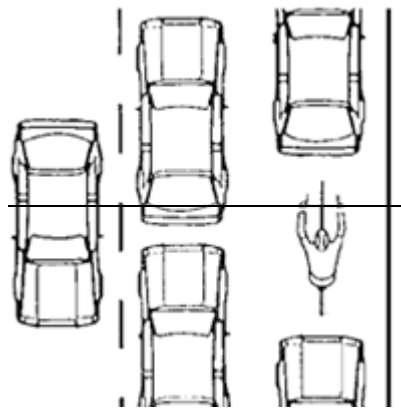

Follow lane markings

Go straight in a through lane, not a right turn only lane. Make left turns from the left lane, if there is one, or the left side of the through lane. Look behind you for traffic and give hand signals before turning.

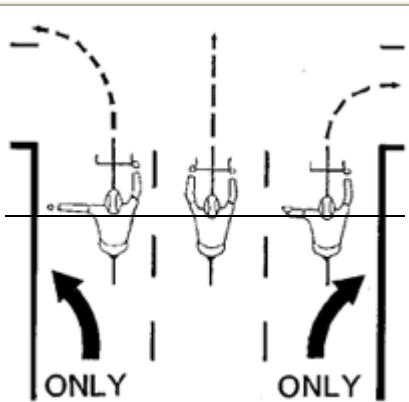

To change lanes

Look behind you for traffic and signal first. Traffic in the lane you want to move into has the right of way. Look back and wait for an opening in traffic before moving over.

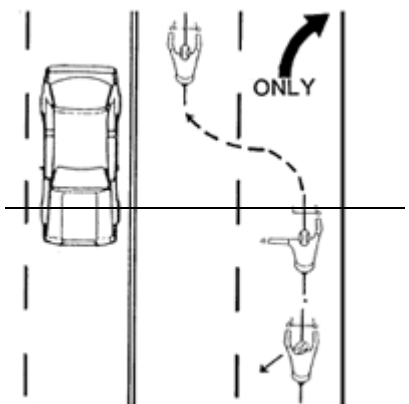

Two ways to make a left turn

(1) Look back for traffic, signal, and move to the left side of the lane when safe. (2) Ride straight through the intersection, dismount at the opposite corner and walk your bike across the street.

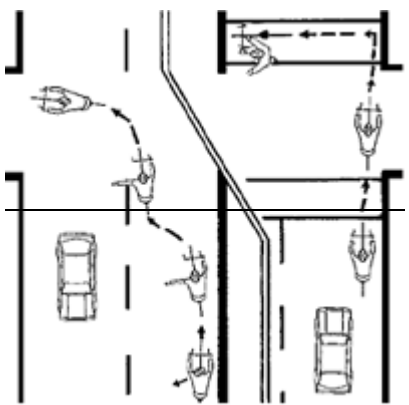

Scan the road ahead

At intersections, watch for turning cars and pedestrians. Mid-block, watch for cars pulling out of driveways, alleys and parking spaces. *Make eye contact* with other drivers. Yield the right of way to pedestrians in crosswalks.

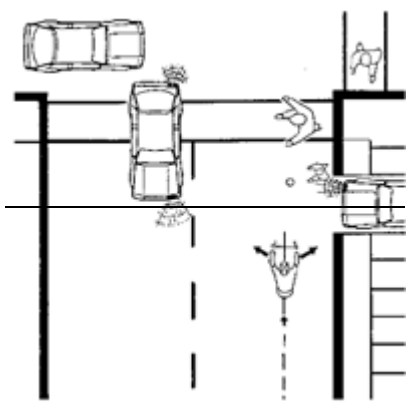

Ride single file

Ride single file when other traffic is present. Riding two-abreast is permitted as long as other traffic is not impeded.

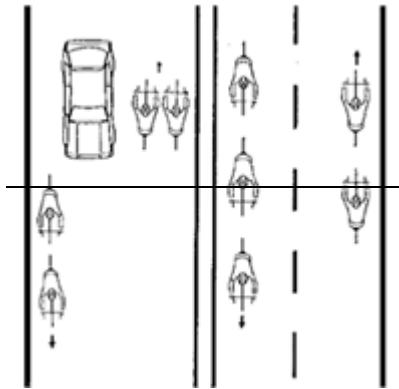

Cross railroad tracks at a right angle

To avoid getting your front wheel caught. Slow down and look behind you for traffic. Change your lane position if necessary to cross the tracks at a right angle. Return to your original lane position after crossing the tracks.

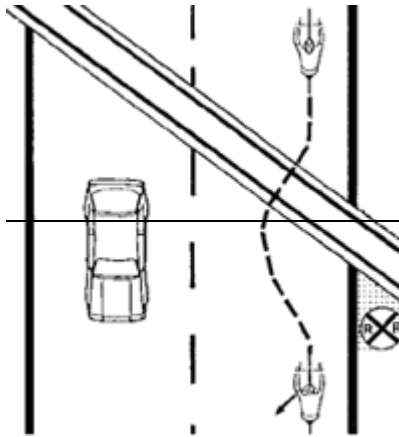

Pass buses on the left

Bus drivers have blind spots to their right and rear. Passing on the right could get you squeezed against the curb if the bus pulls over. Be prepared to stop for pedestrians who may cross the street in front of the bus.

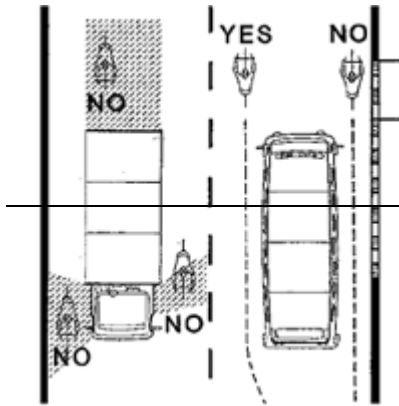

Bicycling on sidewalks is permitted

In some areas local ordinances may prohibit sidewalk riding in commercial districts. Pedestrians always have the right of way on sidewalks and in crosswalks. Give an audible warning before passing pedestrians, and pass with care.

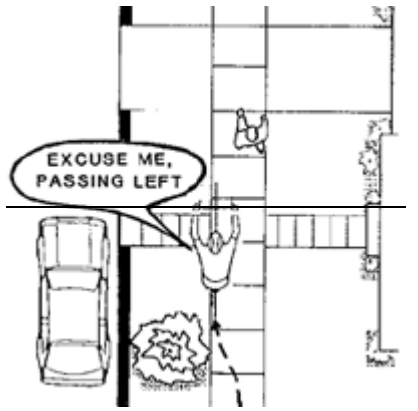

Watch for cars crossing the sidewalk

Watch at driveways, alleys and intersections. Buildings, fences, poles, trees, shrubs, and parked cars can hide you from traffic and make it difficult for you to see them, too. At intersections, you have the same responsibilities as pedestrians.

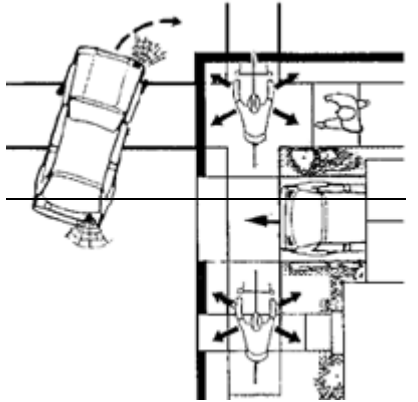

Stop and scan for traffic before entering the street

Stop and scan for traffic before entering the street from a driveway, alley or sidewalk. Look left, right, and left again, and wait for traffic to clear before entering the street.

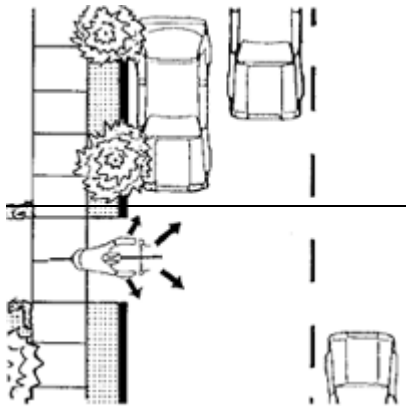

Be visible

At night, a white light to the front and a red rear reflector are required. Additional lights and reflectors can, and should, be used. Bright colors help you to be seen during the day.

